

Alcoa
Fastening
Systems



INSTRUCTION MANUAL

202 ALL MODELS

PNEUDRAULIC INSTALLATION TOOL

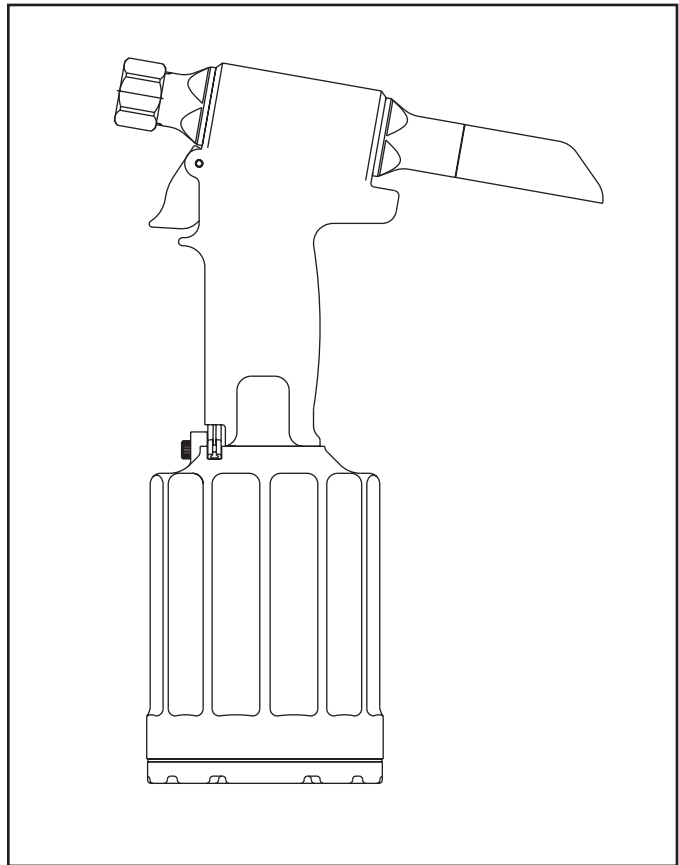

Makers of Huck®, Marson®, Recoil®
Brand Fasteners, Tools & Accessories

02-12-2007
HK938



EU Declaration of Conformity

Manufacturer:

Alcoa Fastening Systems, Commercial Products Division, 1 Corporate Drive, Kingston, NY, 12401, USA

Description of Machinery:

Model number **202** family fastener installation tools

Relevant provisions complied with:

Council Directive related to Machinery, (89/392/EEC), (91/368/EEC), (93/44/EEC), (93/68/EEC)

Council Directive related to EMC/EMI, (89/336/EEC)

European Representative:

Rob Pattenden, Huck International, Ltd. Unit C Stafford Park 7, Telford Shropshire TF3 3BQ, England, United Kingdom

Authorized Signature/date:

I, the undersigned, do hereby declare that the equipment specified above conforms to the above Directive(s) and Standard(s).

Signature: _____



Full Name: Henk Rosier

Position: Engineering Manager
Installation Systems Division

Place: Kingston, New York, USA

Date: June, 2005

Sound Levels

Model: 202

SEL dB (A)	Peak Value dB (C)	Leq dB (A)
84.8	110	72.0

Leq reflects the equivalent noise level result of installing 1,500 typical Huck fasteners for an eight hour work day.

To calculate equivalent noise level for other quantities of fasteners in an eight hour period, use the formula:

Leq = SEL + 10 log (n/28,800)

where n = number of fasteners in eight hours.

Vibration Levels

Model: 202

For an eight hour work day, installing 1,500 typical Huck fasteners will result in an equivalent weighted RMS vibration level A(8) of:

.12 m/s²

To calculate equivalent vibration level for other quantities of fasteners in an eight hour period, use the formula:

Equivalent Vibration Level, A8 (m/s²) = (n/480) x .46

where n = number of fasteners in eight hours, and **.46(m/s²) = Aeq** for 60 seconds.

Test data to support the above information is on file at Alcoa Fastening Systems, Commercial Products Division, Kingston Operations, Kingston, NY, USA. Vibration measurements are frequency weighted in accordance with ISO 8041 (1990).

CONTENTS

EU DECLARATION OF CONFORMITY2

SAFETY4

SPECIFICATIONS5-7

PRINCIPLE OF OPERATION8

PREPARATION FOR USE9

OPERATING INSTRUCTIONS9

SERVICING THE TOOL10

DISASSEMBLY11-13

ASSEMBLY14-15

FILL AND BLEED16

MEASURING TOOL STROKE17

ASSEMBLY DRAWINGS18-19

PARTS LIST20-21

TROUBLESHOOTING22

KITS & ACCESSORIES22

SAFETY

This instruction manual must be read with particular attention to the following safety guide lines, by any person servicing or operating this tool.

1. Safety Glossary

 — Product complies with requirements set forth by the relevant European directives.

 — Read manual prior to using equipment.

 — Eye protection required while using this equipment.

 — Hearing protection required while using this equipment.



WARNINGS - Must be understood to avoid severe personal injury.

CAUTIONS - show conditions that will damage equipment and or structure.

Notes - are reminders of required procedures.

Bold, Italic type and underlining - emphasizes a specific instruction.

2. Huck equipment must be maintained in a safe working condition at all times and inspected on a regular basis for damage or wear. Any repair should be done by a qualified repairman trained on Huck procedures.
3. Repairman and Operator must read manual prior to using equipment and understand any Warning and Caution stickers/labels supplied with equipment before connecting equipment to any primary power supply. As applicable, each of the sections in this manual have specific safety and other information.
4. See MSDS Specifications before servicing the tool. MSDS Specifications are available from you Huck representative or on-line at www.huck.com. Click on Installation Systems Division.
5. When repairing or operating Huck installation equipment, always wear approved eye protection. Where applicable, refer to ANSI Z87.1 - 1989
6. Disconnect primary power source before doing maintenance on Huck equipment.
7. If any equipment shows signs of damage, wear, or leakage, do not connect it to the primary power supply.
8. Make sure proper power source is used at all times.
9. Never remove any safety guards or pintail deflectors.
10. Never install a fastener in free air. Personal injury from fastener ejecting may occur.
11. When using an offset nose always clear spent pintail out of nose assembly before installing the next fastener.
12. If there is a pinch point between trigger and work piece use remote trigger. (Remote triggers are available for all tooling).
13. Do not abuse tool by dropping or using it as a hammer. Never use hydraulic or air lines as a handle. Reasonable care of installation tools by operators is an important factor in maintaining tool efficiency, eliminating downtime, and in preventing an accident which may cause severe personal injury.
14. Never place hands between nose assembly and work piece.
15. Tools with ejector rods should never be cycled with out nose assembly installed.
16. When two piece lock bolts are being used always make sure the collar orientation is correct. See fastener data sheet of correct positioning.

SPECIFICATIONS

Models 202 & 202L

- **Stroke:** .750 in
- **Weight:** 5.1 lbs
- **Air Pressure:** 90 psi
- **Capacity:** 3889 lbs @ 90 psi
- **Speed/Cycles:** 20 per minute

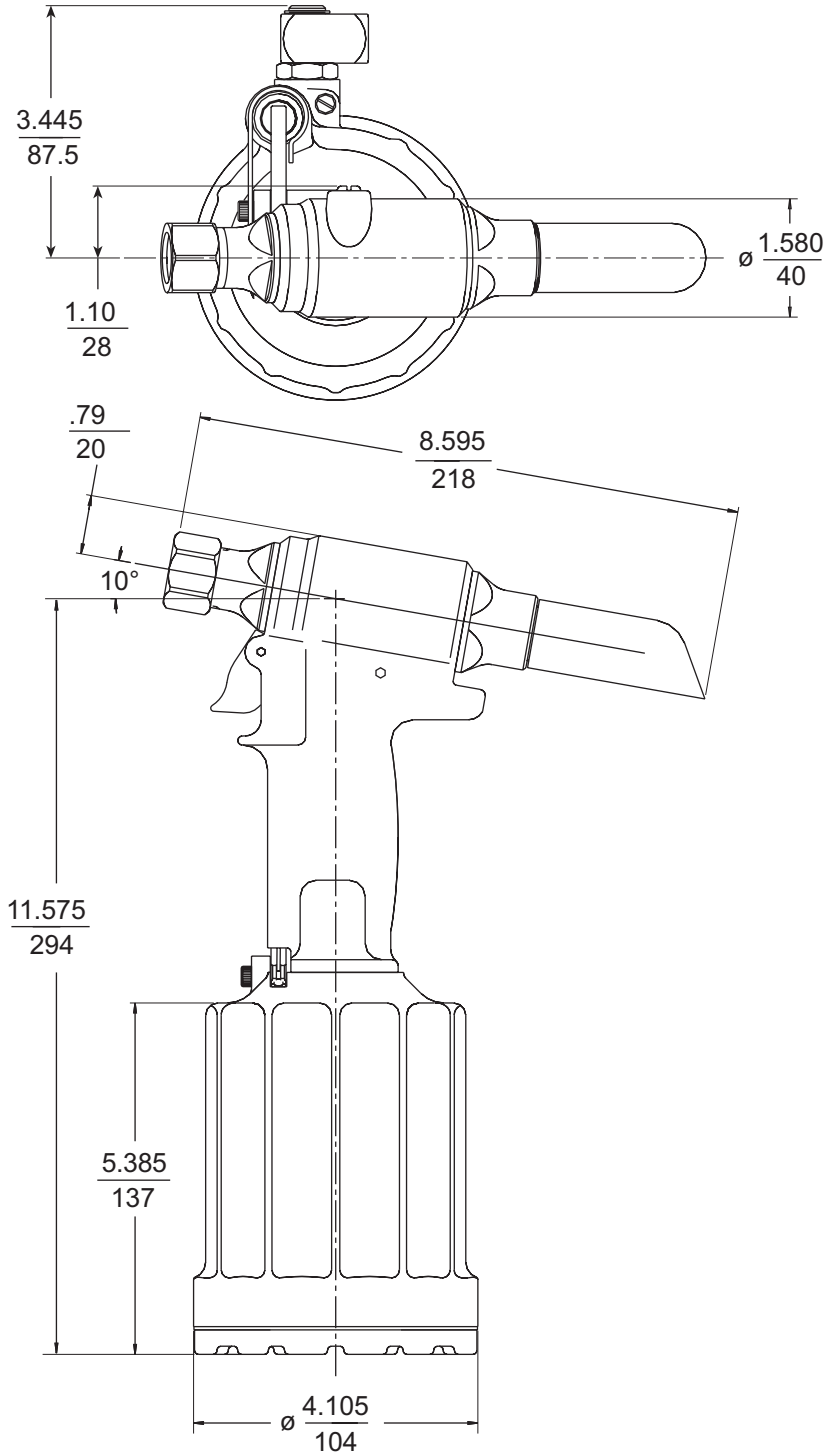

SPECIFICATIONS (CONT.)

Models 202V & 202LV

- **Stroke:** .750 in
- **Weight:** 5.4 lbs
- **Air Pressure:** 90 psi
- **Capacity:** 3889 lbs @ 90 psi
- **Speed/Cycles:** 20 per minute

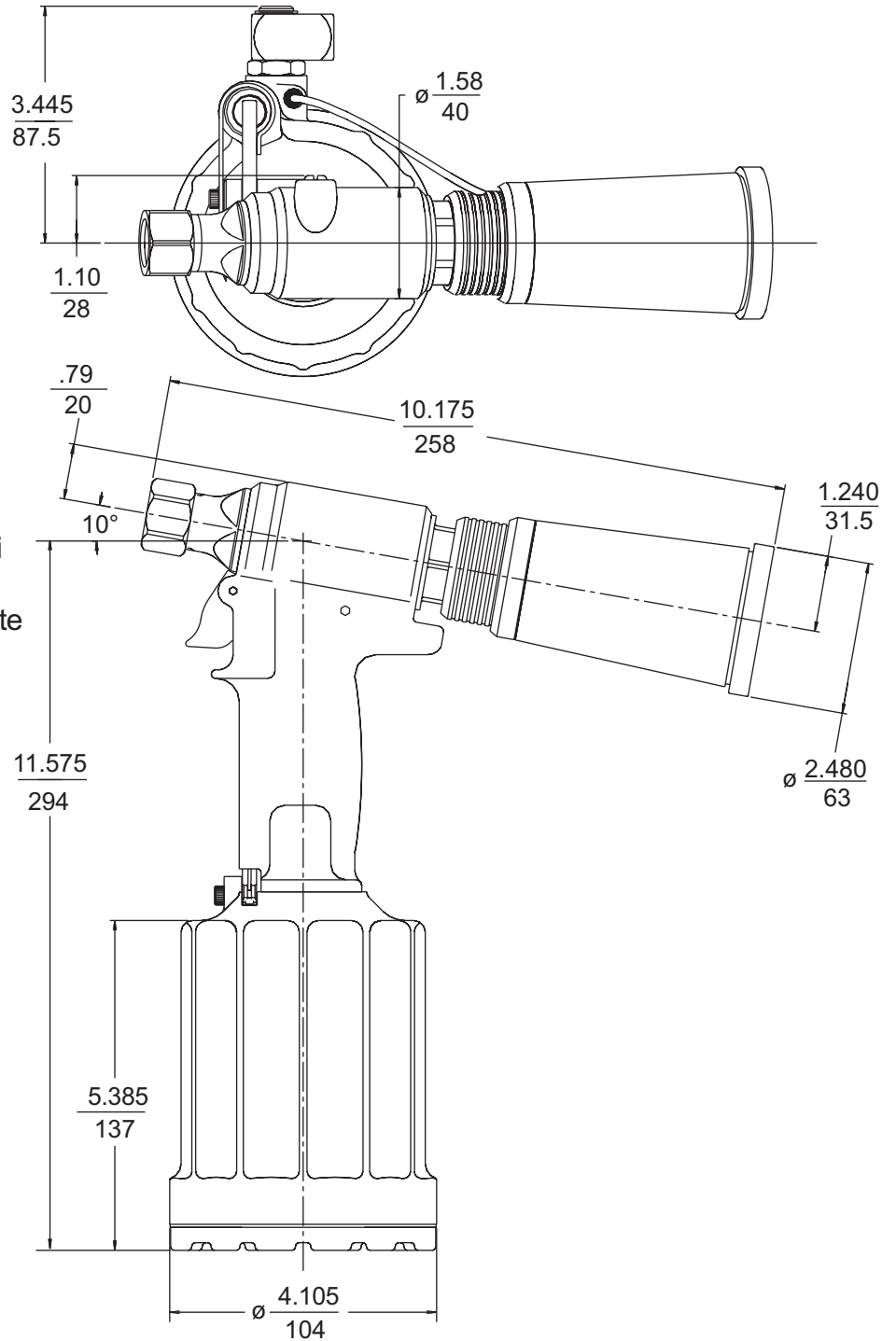

SPECIFICATIONS (CONT.)

Model 202B

- **Stroke:** .750 in
- **Weight:** 5.4 lbs
- **Air Pressure:** 90 psi
- **Capacity:** 3889 lbs @ 90 psi
- **Speed/Cycles:** 20 per minute

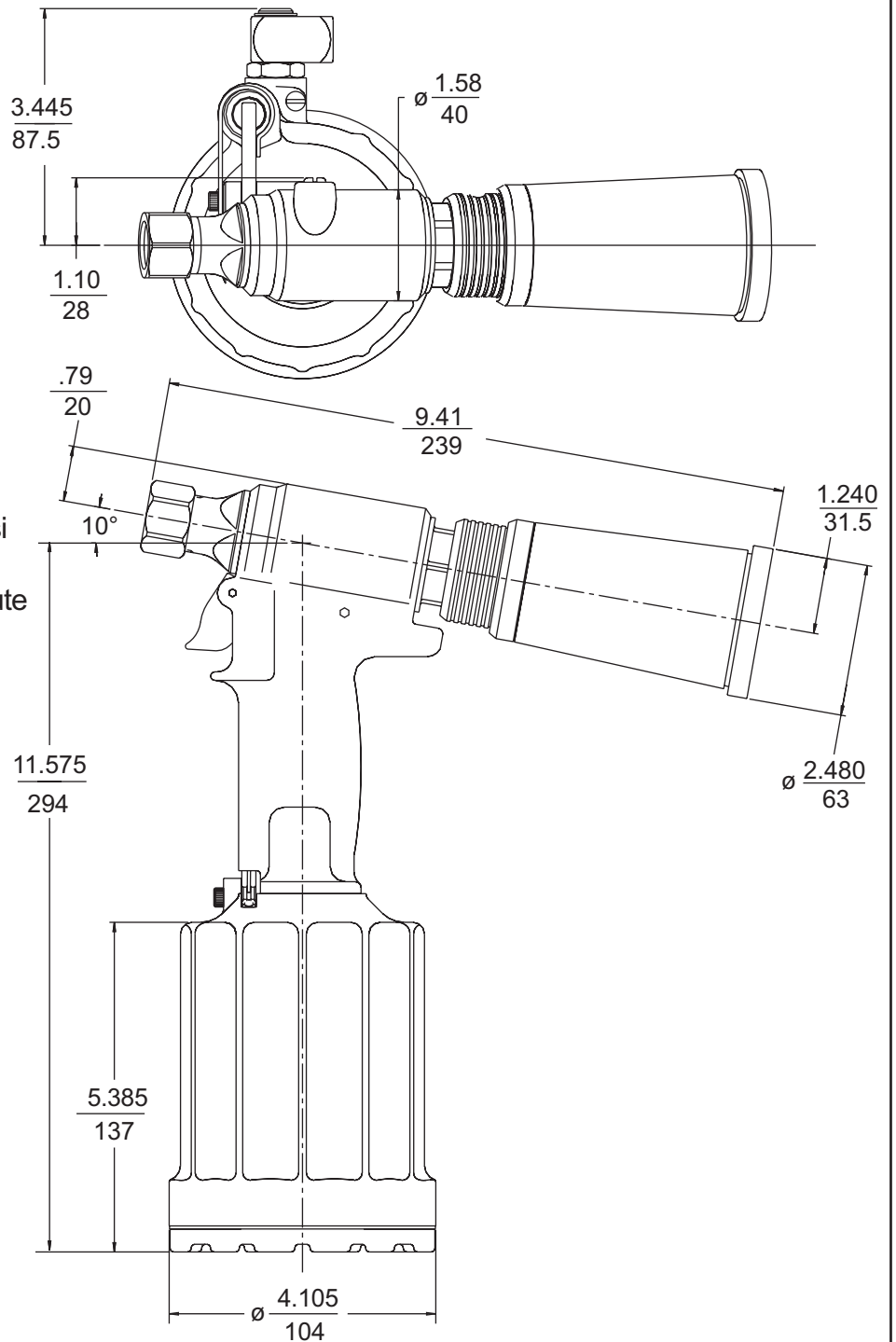

PRINCIPLE OF OPERATION

When the tool is connected to proper air supply, the air pressure holds the Throttle Valve in the up (RETURN) position.

KEY

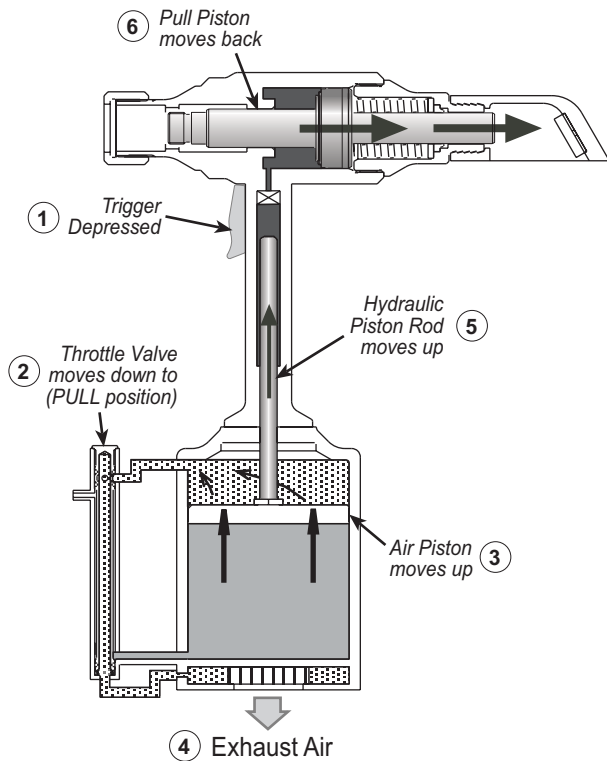
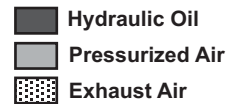

PULL Stroke

When the Trigger is depressed¹ the Throttle Valve moves to down (PULL) position², and pressurized air is directed to the bottom of the Air piston, causing it to move upward.³

The air above the Air Piston is exhausted and directed through the center of the Throttle Valve and out the bottom of the tool.⁴

As the Hydraulic Piston Rod moves upward⁵, a column of fluid is forced into head, which moves the Pull Piston back.⁶

The attached nose assembly moves with the Pull Piston to start fastener installation.

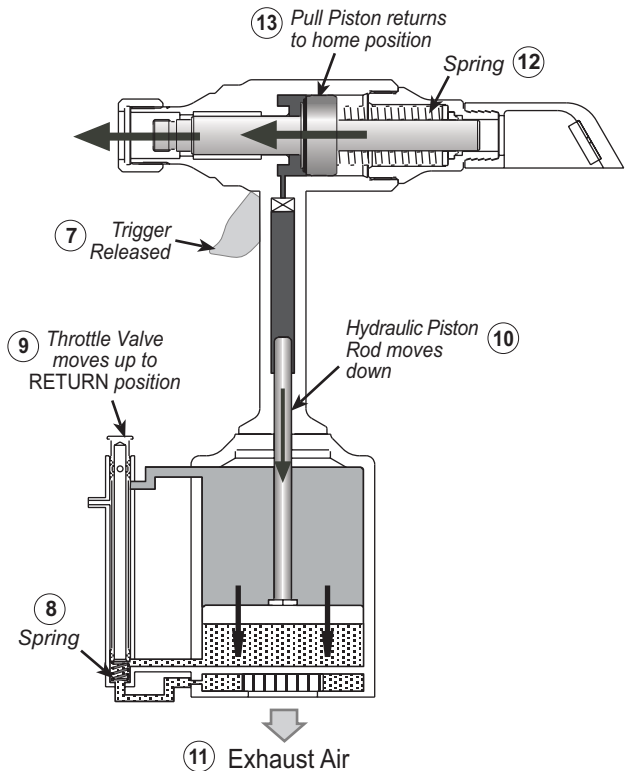

RETURN Stroke

When fastener installation is completed, the Trigger is released.⁷

Air pressure, with the assistance of a Spring⁸, causes the Throttle Valve to return to its up position.⁹

Pressurized air is re-directed to the top of the Air Piston, causing the Air Piston and Hydraulic Piston Rod to move downward.¹⁰

The air from below the Air Piston is exhausted through the bottom of the tool.¹¹

Spring¹² pressure returns the Pull Piston to its home position.¹³



PREPARATION FOR USE

The Model 202 Installation Tool is shipped with a plastic plug in the air inlet connector. The connector has 1/4-18 female pipe threads to accept the air hose fitting. Quick disconnect fittings and 1/4" inside diameter air hose are recommended. An air supply of 90 - 100 psi capable of 20 CFM must be available. Air supply should be equipped with a filter-regulator-lubricator unit.

1. Remove plastic shipping plug from Air Inlet Connector and put in a few drops of Automatic Transmission Fluid, DEXRON III, or equivalent.
2. Screw quick disconnect fitting into Air Inlet Connector.
CAUTION: Do not use TEFLON tape on threads. Use TEFLON in stick form only. (Huck P/N 503237)
3. Set air pressure on regulator to 90-100 psi.
4. Connect air hose to tool.
5. Cycle tool a few times by depressing and releasing trigger.
6. Disconnect air hose from tool.
7. Remove Retaining Nut at front of tool.

8. Select proper Nose Assembly from the available **NOSE ASSEMBLY SELECTION CHART** for fastener to be installed.
9. Screw Collet Assembly (including lock collar and shim if applicable) onto Spindle. (Wrench Tight)
10. Slide Anvil over Collet Assembly and into counterbore.
11. Slide Retaining Nut over Anvil and screw Nut onto Head.
12. Connect air hose to tool and install fastener(s) in test plate of proper thickness with proper size holes. Inspect fastener(s).

NOTES:

- 1 Air quick disconnect fittings and air hoses are not available from Huck International, Inc.
- 2 On old style nose assemblies with lock collars, **VIBRA-TITE** should be used on collet threads, since there is no staking hole provided on the 202 Pull Piston.



OPERATING INSTRUCTIONS

NOTE: 202V and 202VL are sold with the ribbed vacuum control ON/OFF slide in the forward or OFF position. See Figure 10 for slides location which is shown in the ON (rear) position. While tool is not being used, move slide to the OFF (forward) position to prevent unnecessary air loss.

Blind Fastener Installation:

The fastener may be placed either in the work hole or in the end of the nose assembly. In either case, tool and nose assembly must be held against work and at right angles to it. Depress trigger and hold it depressed until fastener is installed and pintail breaks. Release trigger.

MAGNA-GRIP® Fastener Installation:

Place pin in work-hole and place collar over pin. See **WARNINGS**. (If collar has only one tapered end, that end **MUST** be out toward tool.) Hold pin in hole. Push nose assembly onto pin protruding from collar until anvil touches collar. Press trigger and hold down until collar is swaged and pintail breaks. Release trigger.

CAUTION: Remove excessive gap from between sheets for enough of the pintail to stick out of the collar for *all of the jaw teeth to grip into the pintail grooves*. Jaws not fully gripping pintail grooves will be stripped or broken.



WARNINGS

Inspect tool for damage or wear before each use. Do not operate if damaged or worn as severe personal injury may occur.

Pulling on a pin (fastener) without a collar, or with collar chamfer against workpiece, may result in pin becoming a high speed projectile when pin grooves are stripped or pintail breaks off. *Fatal or severe injury is possible to anyone in the pins line of flight. This includes pins that ricochet.*

Broken pintails eject from deflector with speed and force. *Be sure pintail deflector is directed safely away front operator or the personnel in the area. Ejecting pintails striking anyone may cause serious personal injury. For Models 202B and 202V, pintail bottles must always be used. Replace damaged pintail deflectors and bottles as serious personal injury may occur from pintails when using these defective parts.*



SERVICING THE TOOL

General

1. The efficiency and life of any tool depends upon proper maintenance. Regular inspection and correction of minor problems will keep tool operating efficiently and prevent downtime. The tool should be serviced by personnel who are thoroughly familiar with how it operates.
2. A clean, well-lighted area should be available for servicing the tool. Special care must be taken to prevent contamination of pneumatic and hydraulic systems.
3. Proper hand tools, both standard and special, must be available.
4. All parts must be handled carefully and examined for damage or wear. **Always replace Seals, O-rings, and Back-up Rings when tool is disassembled for any reason.** Components should be disassembled and assembled in a straight line without bending, cocking, or undue force. Disassembly and assembly procedures outlined in this manual should be followed.
5. **Service Parts Kits 202KIT, 202BKIT, and 202VKIT** include consumable parts and should be available at all times. Other components, as experience dictates, should also be available.

Daily

1. If a Filter-Regulator-Lubricator unit is not being used, uncouple air disconnects and put a few drops of Automatic Transmission Fluid or light oil into the air inlet of the tool. If the tool is in continuous use, put a few drops of oil in every two to three hours.
2. Bleed the air line to clear it of accumulated dirt or water before connecting air hose to the tool.
3. Check all hoses and couplings for damage or air leaks, tighten or replace if necessary.
4. Check the tool for damage or air/hydraulic leaks, tighten or replace if necessary.
5. Check the nose assembly for tightness or damage, tighten or replace if necessary.
6. Check stroke periodically, if stroke is short add oil.

Weekly

1. Disassemble and clean nose assemblies and reassemble per applicable NOSE ASSEMBLY instructions.
2. Check the tool and all connecting parts for damage or oil/air leaks, tighten or replace if necessary.



DISASSEMBLY - ALL MODELS



WARNING: Be sure air hose is disconnected from tool before cleaning, or performing maintenance. Severe personal injury may occur if air hose is not disconnected.

For component identification, refer to Figures 14 & 15 and Parts Lists on pages 20 & 21.

NOTE: The following procedure is for complete disassembly of tool. Disassemble **only** components necessary to replace damaged O-rings, Quad rings, Back-up rings, and worn or damaged components. Always use soft jaw vice to avoid damage to tool.

1. Disconnect tool from air source.
2. Unscrew Retaining Nut (7) and remove nose assembly.
3. Unscrew Bleed Plug (55), from top of Handle/head. Turn tool over and allow fluid to drain into container (Fig. 1). Discard fluid.

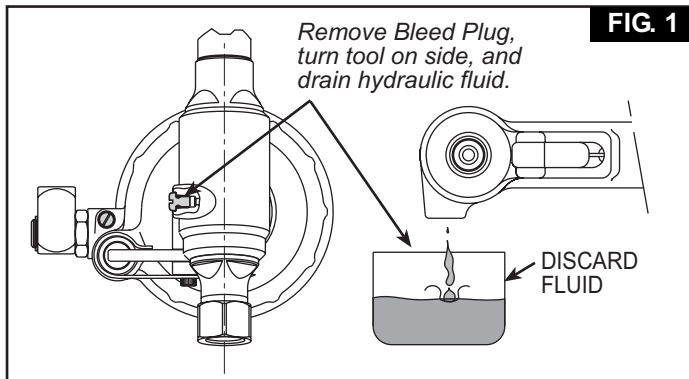

4. **For 202 & 202L:** Pull Pintail Deflector (24) off of End Cap (21). (Figure 2)
For 202B: By reaching through the window of Pintail Bottle (24) remove Retaining Ring (62) and Washer (63), then remove Pintail Bottle (24) and Adapter (64). (Figure 5).
For 202V & 202LV: Please reference *Disassembly of Pintail Bottle and Vacuum System Procedure*.

5. Remove Throttle Arm Pivot Screw (48) and Lever Guard (73), and lift out Throttle Arm (53). Disconnect ball end of Cable Assembly (2) from Throttle Arm.
6. Hold tool in vise with bottom up. (Fig. 2) Remove Button Head Screws (40) with 1/8 hex key. Remove End Cap (41) and Gasket (39). Remove Muffler (42) from end cap. Remove Spring (49) from Throttle Valve (Fig.14).

7. Tap Cylinder Head (45) down with soft mallet (to take pressure off ring), and remove Retaining Ring (38) (Fig.2).
8. Screw Button Head Screws (40) back into Cylinder Head. Carefully pry on screws to remove head. Remove O-ring (46).

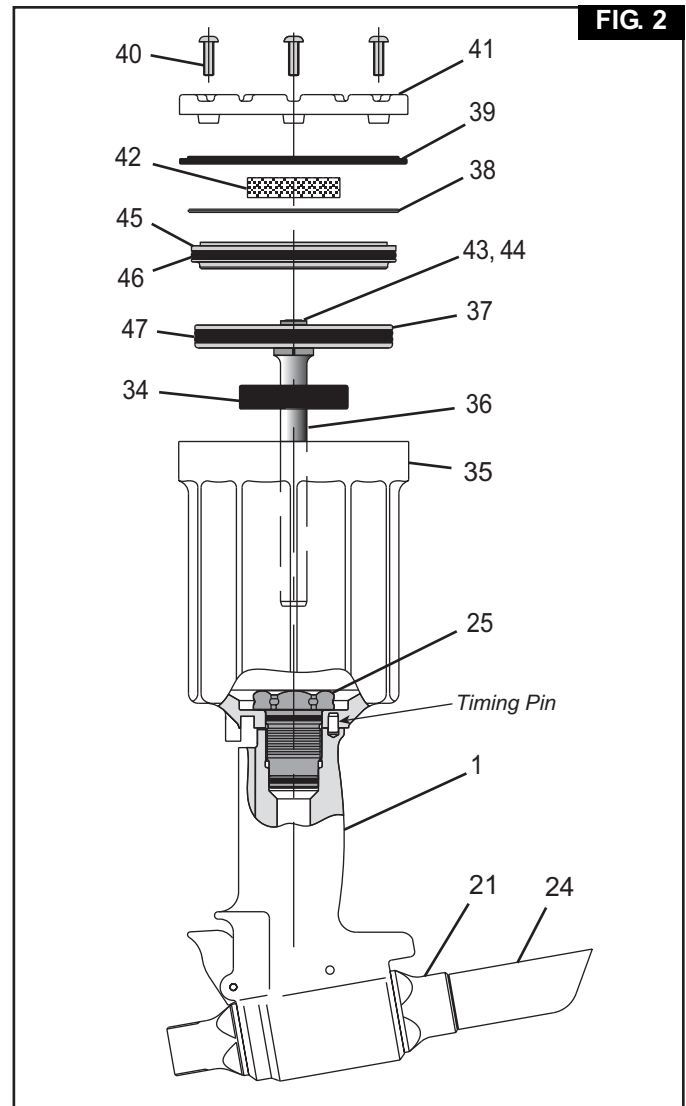

9. To remove air piston from cylinder, pull on Lock Nut (43) with vise grips. Remove Piston Quad Ring (47). **CAUTION: Care must be taken not to scratch piston rod or cylinder during removal.**
10. Remove Bumper (34) from Gland Assembly. Unscrew Gland Assembly (25) with 1 3/8 socket wrench and extension bar.



DISASSEMBLY - ALL MODELS *continued*

11. First remove Retaining Ring (30) from Gland (26). Pull out Spacer (29) and Polyseal (28). Then remove O-rings (31 & 27), Quad Ring (33), & Back-up Ring (32) (Fig. 14).
12. Lift Cylinder (35) from handle/head (1) (Fig. 2).
13. Turn handle/head (1) over and drain fluid into container. Discard fluid.
14. Pull Throttle Valve (52) out of air Cylinder (35). Remove O-Rings (50) (Fig. 14).

Head/handle 202 & 202L:

15. Unscrew End Cap (21) and remove Spring (19), Spacer (22) and Wiper Seal (23). **NOTE: For 202V please reference Disassembly of Pintail Bottle and Vacuum System procedure.**
16. Thread POLYSEAL Insertion/removal Tool (121694-202), into rear of Handle/head. (Figure 3)

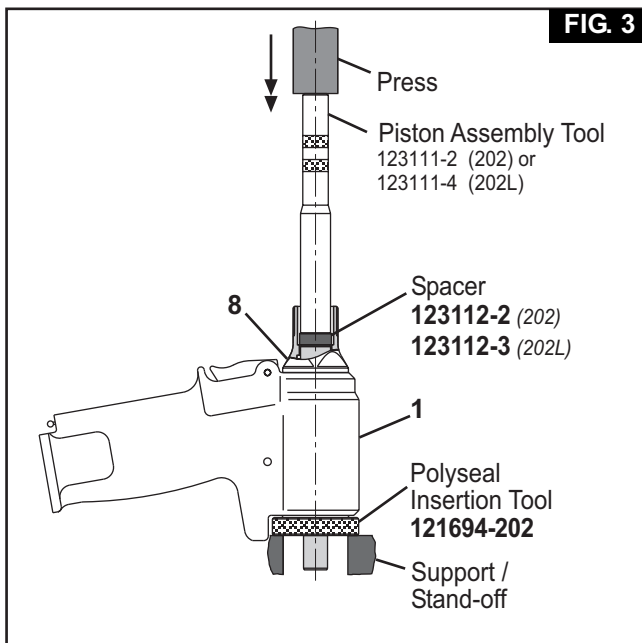

17. Slide Spacer (123112-2 for 202 or 123112-3 for 202L) onto piston.
18. Thread Piston Assembly Tool (123111-2 for 202 or 123111-4 for 202L) onto piston.

19. Push piston and front gland assemblies out the back of the Handle/Head (1). Allow clearance, with stand-off, for piston as it leaves the tool (Figure 4).

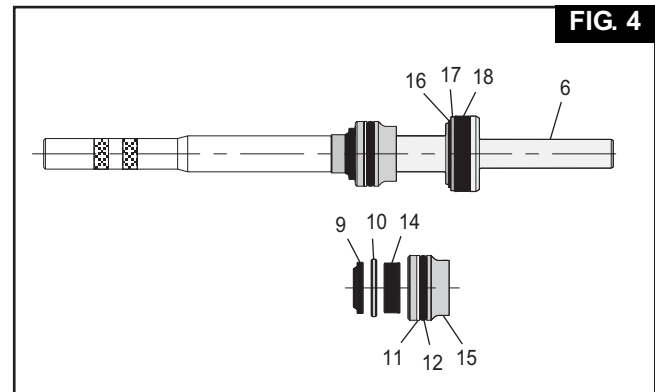

20. Remove piston assembly tool and spacer from piston. Rethread on the piston assembly tool only, then slide the front gland assembly off the Piston (6) (Figure 4).
21. Remove Piston Assembly Tool from Piston (6). Remove POLYSEAL Insertion/removal Tool from rear of Head/Handle (1).
23. Remove Retaining Ring (16), Washer (17) and POLYSEAL (18) from piston.
NOTE: Inspect hydraulic piston for wear, scoring or damage. Replace when necessary.
24. Unscrew Adapter (8) (Figure 14).
25. Inspect all seals and parts.
24. If frayed or broken, remove trigger Cable Assembly (2) by driving Pin (4) out with punch. Remove Dowel Pin (3) to disconnect cable from trigger.



DISASSEMBLY - ALL MODELS *continued*

Pintail Bottle/Vacuum System

202V & 202LV (Refer to Figures 5, 6 & 15)

NOTE:

The following steps are for the disassembly of the 202V and 202LV models only. Please use these steps in conjunction with the General and Head/Handle disassembly sections of this manual.

1. By reaching through the window of Pintail Bottle (24) remove Retaining Ring (62) and Washer (63) (Figure 5).

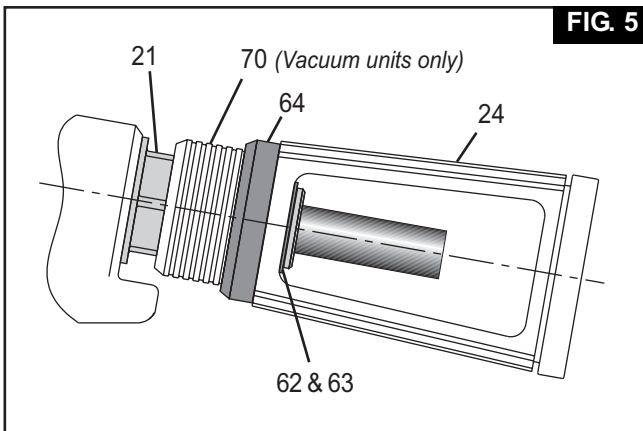

2. Remove Pintail Bottle (24).
3. Disconnect tube from Plug & Gasket Assy (54) (Figure 15).
4. Remove Adapter (64) and Tube/ Slide Assembly (70).
5. Remove End Cap (21) and Spring (19) (Figure 6).

6. Remove Spacer (22) and O-Ring (68) from spring side of end cap.
7. From bottle side of end cap, remove Retaining Ring (66), Tube (67), Wiper Seal (23), Washer (71) and O-Ring (69).
8. Remove the O-Rings (65) from the inside of the Adapter and Tube/Slide Assembly (70) (Figure 15).

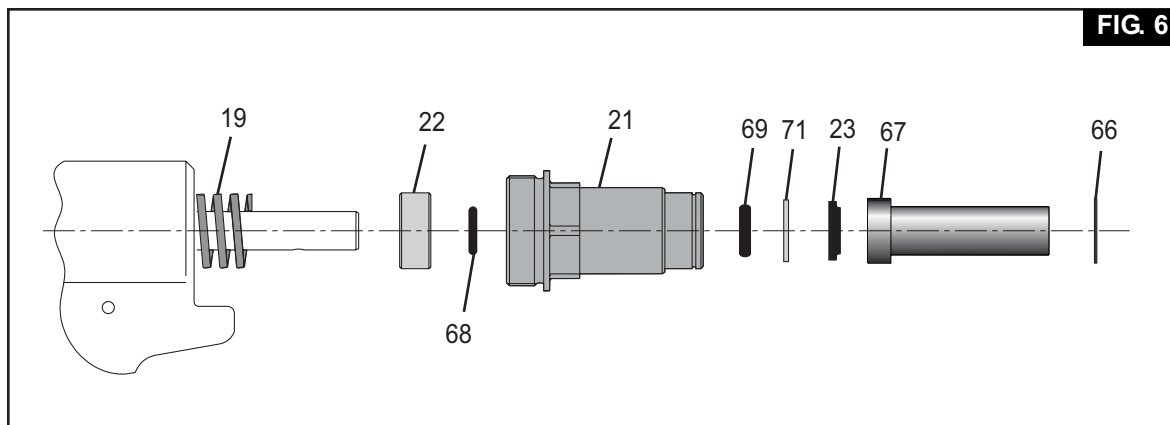



ASSEMBLY - ALL MODELS

Head/handle 205, 202B, & 202L

NOTE: Clean components with mineral spirits, or similar solvent; inspect for wear/damage and replace as necessary. Replace all seals of disassembled components. Use O-rings, QUAD rings and Back-up rings in **Service Parts Kit, P/N 202KIT or 202VKIT** Smear LUBRIPLATE 130AA or PARKER-O-LUBE on O-rings, QUAD rings, Back-up rings and mating parts to ease assembly. Assemble tool taking care not to damage O-rings, QUAD rings, or Back-up rings.

1. If removed, position Cable Assembly (2) in Trigger (5) slot and slide Dowel Pin (3) through holes in trigger and cable assembly. Position assembled trigger in handle and drive Pin (4) through holes in handle and trigger (Figure 14).
2. Screw Nose Adapter (8) into Head (1) and tighten.
3. Thread POLYSEAL Insertion/removal Tool (121694-202) into head.
4. Assemble piston (6), Polyseal (18) and retaining ring (16) (Figure 7). **Note Polyseal orientation.**

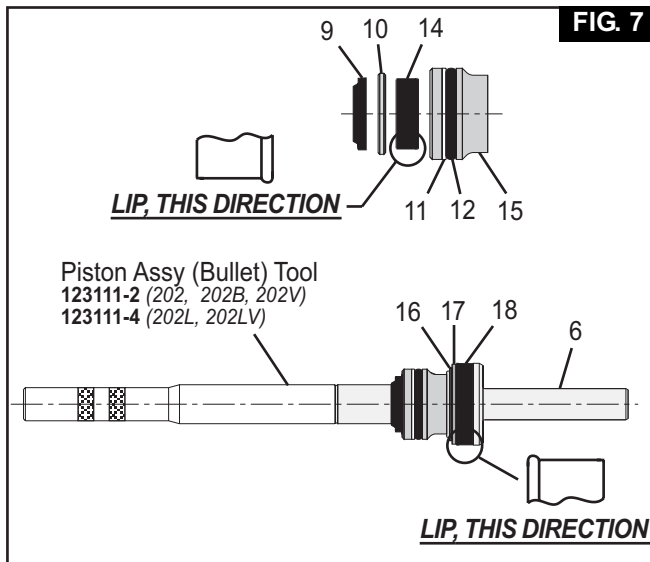

5. Assemble front gland (15), O-ring (12), Back-up ring (11), Polyseal (14) and Gland Cap (10). **Note Polyseal orientation.**
6. Thread Piston Assembly Tool (123111-2 for 202, 202B & 202V) or (123111-4 for 202L & 202LV) onto Piston (6). Slide complete Gland Assembly and Wiper Seal (9) onto Piston (6).

7. Install assembled components in gently from rear of tool using a press as shown in (Figure 8).

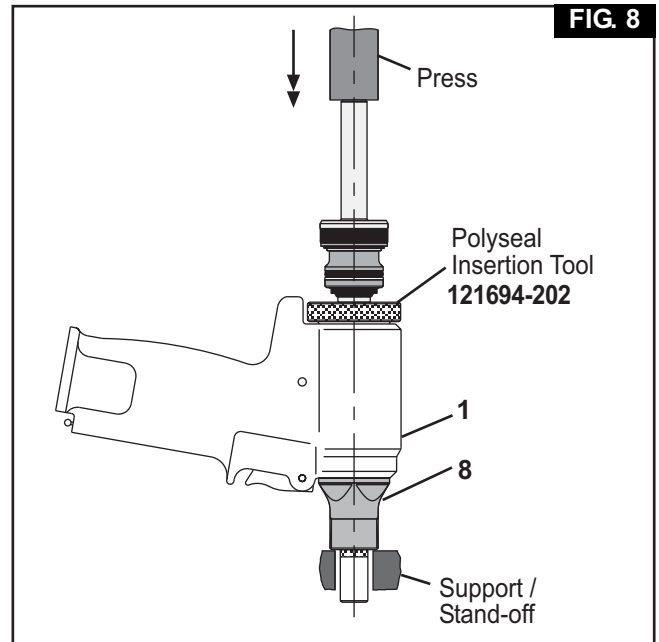

8. Remove Piston Assembly Tool (123111-2 or 123111-4) and POLYSEAL Insertion / removal (121694-202) Tool.
9. Install Rear Wiper Seal (23) into End Cap (21) (Figure 14).
10. Slide Spacer (22) and Spring (19) into End Cap (21) and then thread End Cap assembly into rear of Head.
NOTE: For 202V and 202VL, please reference Assembly of Pintail Bottle and Vacuum System procedure.

General:

(Refer to Figures 2 & 9)

11. Hold Head/Handle (1) inverted in vice (with soft jaws). Place inverted Cylinder Assembly (35) on base of handle. Timing pin maintains orientation.
12. Assemble Gland assembly (25) with new seals (Fig. 9). Note orientation of polyseal. Apply Anti-Seize Compound (Huck P/N 508183) to threads of Gland Assembly. Screw gland into head/handle and Torque to 50 ft. lbs. using 1 3/8 socket wrench.(40) using 1/8 hex key (Fig. 2).



ASSEMBLY - ALL MODELS *continued*

13. Push Bumper (34) firmly over gland.
NOTE: The side of the bumper with two slots must face toward the bottom of the tool.
 14. Install Quad Ring (47) onto Air Piston (37).
 15. Lubricate piston rod. Press assembled air piston/rod into cylinder just enough to allow installation of cylinder head (45).
 16. Assemble O-Ring (46) onto Cylinder Head (45) and then push Cylinder Head squarely into cylinder taking care not to damage O-ring (46). Install Retaining Ring (38). (*Align screw holes with muffler end cap*)
 17. Position Muffler (42) in center of cylinder head. Position Gasket (39) on cylinder. (Refer to Fig 2 & 9) Note direction of Lip
 18. Carefully position Bottom Plate (41) on cylinder.
NOTE:
Make sure that the muffler is properly positioned in recess of Bottom Plate (41) (Fig 2 & 14).
 19. Secure the bottom plate with the three Button Head Screws (40) using 1/8 hex key (Fig. 2).
 20. Assemble O-Rings (72 & 50) on Throttle Valve (52). (Fig. 14 Section CC)
 21. Place the tool upright on a level surface, drop Spring (49) into throttle valve bore in cylinder (35). Push Throttle Valve into cylinder.
 22. Place ball end of Throttle Cable (2) into end of Throttle Arm (53), then slide Throttle Arm into slot on Cylinder (Fig. 9).
 23. Snap Lever Guard (73) in place, and install Pivot Screw (48) in cylinder to retain throttle arm (53).
 24. **For 202 & 202L:** Push Pintail Deflector (24) onto End Cap (21).
For 202B: Position Adapter (64) and Pintail Bottle (24) on End Cap and, by reaching through the window of the Pintail Bottle, install Washer (63) and Retaining Ring (62) (Figures 14 & 15).
For 202V & 202LV: Please reference Disassembly of Pintail Bottle and Vacuum System Procedure.
 25. Tool is now completely assembled and needs to be filled with oil. Please refer to the fill and bleed section next.
- Pintail Bottle/Vacuum 202V & 202LV:***
(Refer to Figures 6 & 15)
The following steps are for the assembly of the 2025V & 2025LV models only. Please use these steps in conjunction with the General and Head/Handle disassembly sections of this manual.
1. Assemble Adapter and Tube/Side Assembly (70) and new O-Rings (65).
 2. From bottle side of End Cap (21) install O-Ring (69), Washer (71), Wiper Seal (23), Wiper Housing (67) and Retaining Ring (66) as shown in (Fig. 6).
 3. From tool side of end cap install O-Ring (68), Spacer (22) and Spring (19). (as shown in Fig. 6) Screw entire assembly into head and tighten.
 4. Assemble Tube/Slide Assembly and O-rings (65), slide complete assembly onto End Cap (21) and push tube into connector (54) (Fig.15).
 5. Position Adapter (64) and pintail bottle (24) on End Cap (21) (Fig. 5 & 15).
 6. By reaching through the window of the Pintail Bottle (24), install Washer (63) and Retaining Ring (62) as shown in (Fig. 5).

FILL AND BLEED - ALL MODELS

Equipment Required:

- Shop airline with 90 - 100 psi max.
- Air regulator
- Fill bottle, 120337, (supplied with tool).
- Large flat blade screwdriver
- Optional Stall Nut 124090 or 125340
- Nose assembly
- Fasteners (optional)



WARNING: Avoid contact with hydraulic fluid. Hydraulic fluid must be disposed of in accordance with Federal, State and Local Regulations. Please see MSDS for Hydraulic fluid shipped with tool.

Preparation:

- Install air regulator in airline and set pressure to 20-40 psi.
- Fill bleed bottle almost full of DEXRON III ATF or equivalent.

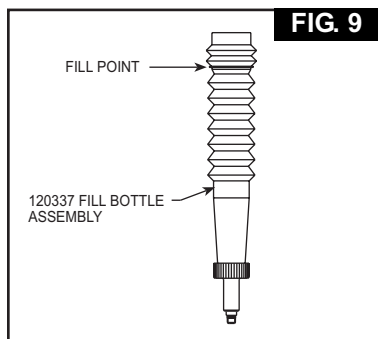

Caution: Refill using Automatic Transmission Fluid DEXRON III or equivalent for optimal performance.

Step 1

With fill port facing up, lay tool on it's side, and remove bleed plug (55) from bleed port.

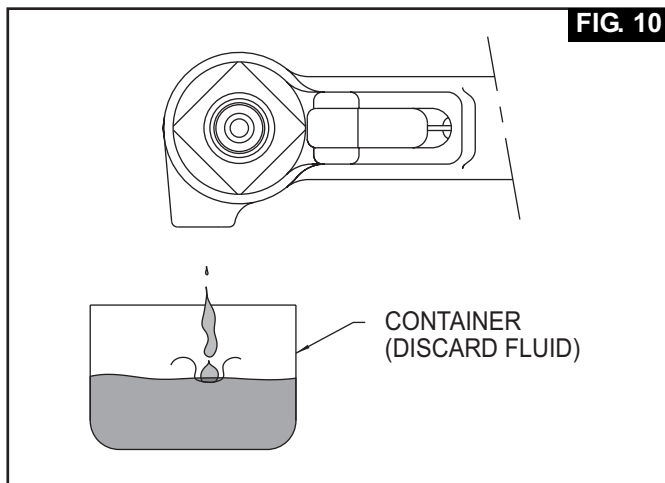

Step 2

Connect tool to shop air set at 20 to 40 psi. If fluid is present, hold tool over suitable container with fill port facing into container. Cycle tool several times to drain the old fluid, air and foam (Figure 10)

Caution: All oil must be purged from tool before Fill & Bleed process. Tool stroke will be diminished if oil is aerated.



WARNING: Air pressure MUST be set to 20 to 40 psi to prevent possible injury from high pressure spray. If plug (55) is removed, fill bottle must be in place before cycling tool.

Step 3

Screw fill bottle (120337) into fillport.

Step 4

Stand tool upright on bench. While triggering tool slowly (20-30 cycles), bend fill bottle at right angles to tool. (Figure 11) Air bubbles will accumulate at top of the bottle. When bubbles stop, cycling may be discontinued.

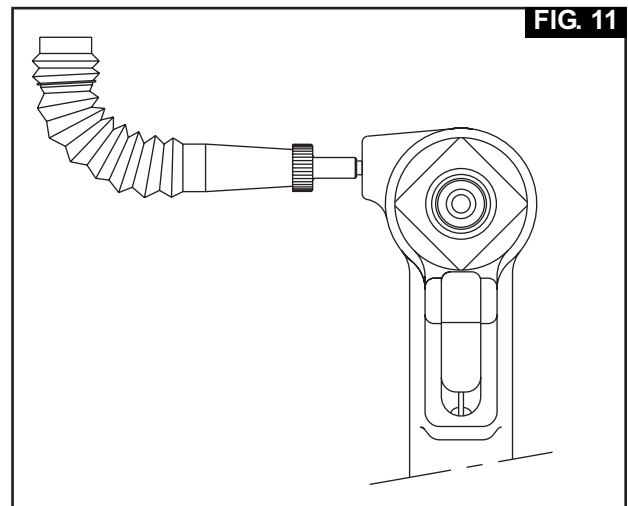

Step 5

When trigger is released, pull piston returns to idle position (full forward). Disconnect tool from airline.

Step 6

Lay tool on it's side and remove fill bottle. Top off fluid in fill port, install bleed plug and tighten.

Step 7

Connect airline to tool and measure the tools stroke, refer to the Measuring Tool Stroke section. If stroke is less than specified, remove bleed plug and top off fluid. Reinstall bleed plug and recheck stroke.

Step 8

Increase air pressure to specifications. Install two fasteners to check function and installation in a single stroke, or cycle tool with stall nut fully threaded onto piston to load up tool. Measure stroke again. Remove plug and top off fluid. Reinstall plug and cycle and measure again. Continue this process until stroke meets minimum requirements.

MEASURING TOOL STROKE

FIG. 12

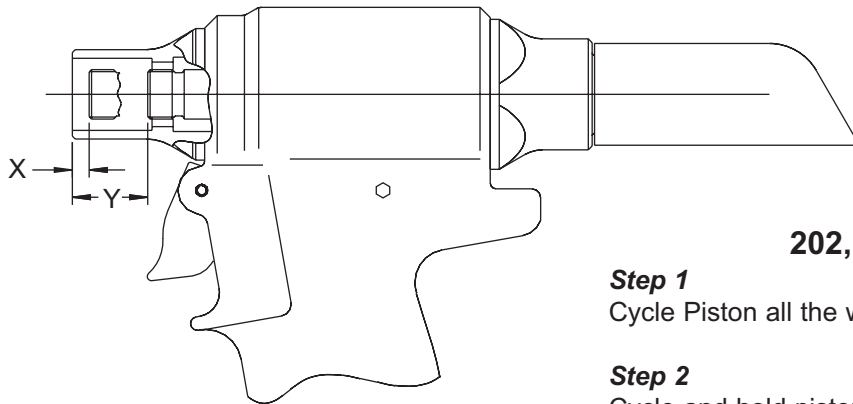

202, 202B, & 202V

- Step 1**
Cycle Piston all the way forward and measure X.
- Step 2**
Cycle and hold piston back and measure Y.
- Step 3**
Stroke = Y-X

FIG. 13

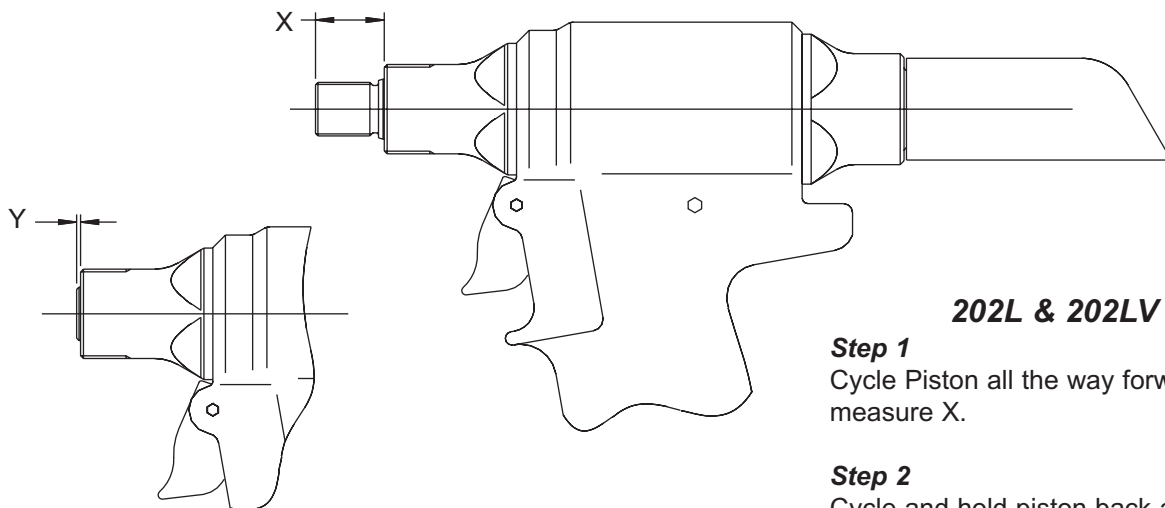

202L & 202LV

- Step 1**
Cycle Piston all the way forward and measure X.
- Step 2**
Cycle and hold piston back and measure Y.
- Step 3**
Stroke = X-Y

FIG. 14

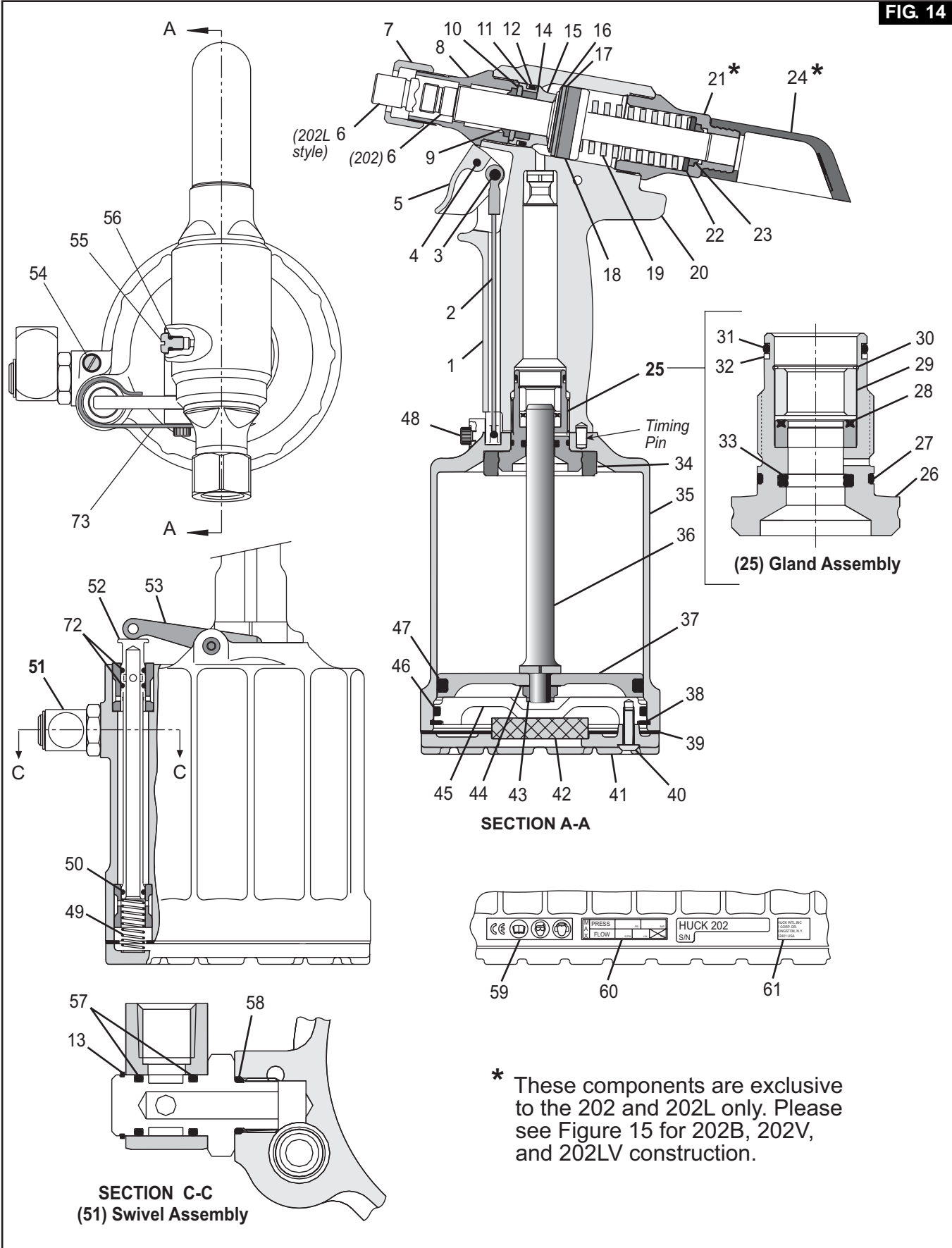

* These components are exclusive to the 202 and 202L only. Please see Figure 15 for 202B, 202V, and 202LV construction.

FIG. 15

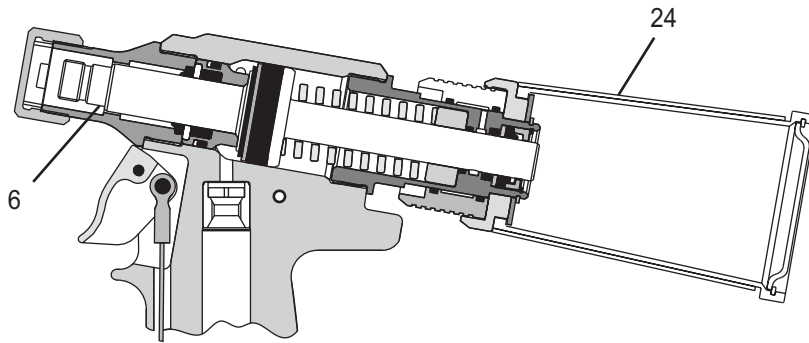
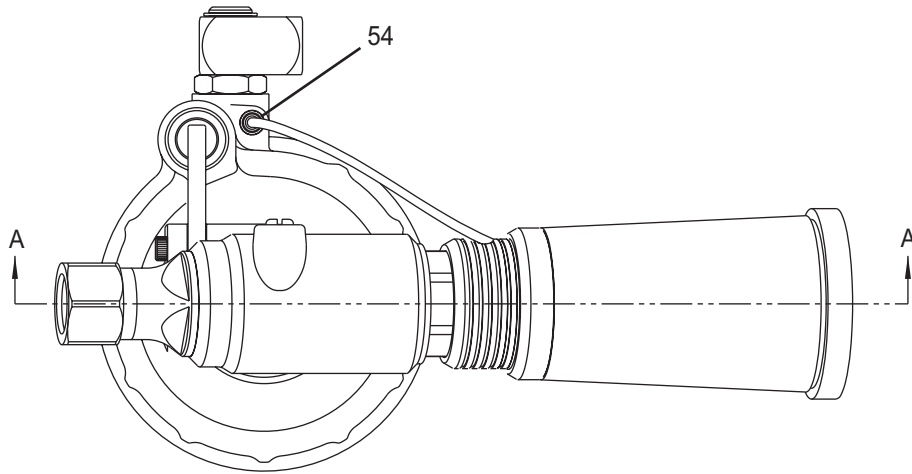

PARTIAL SECTION A-A
Bottle Unit 202B

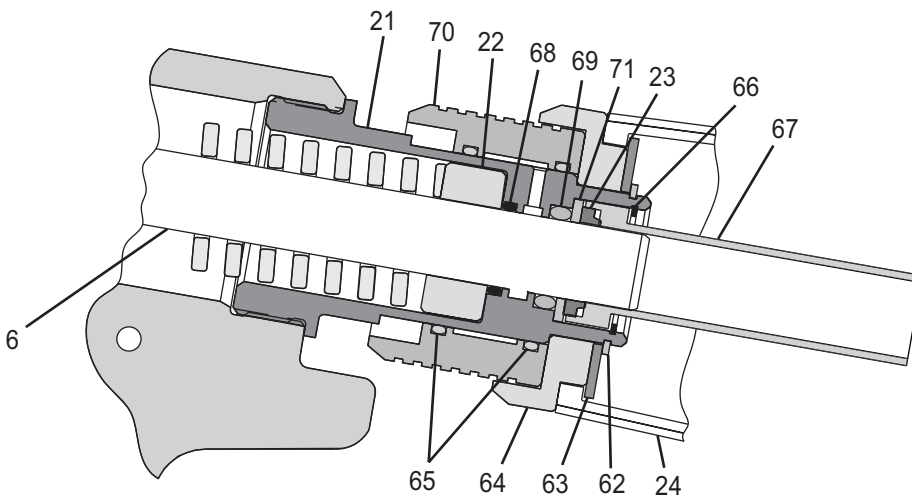

PARTIAL SECTION A-A
Vacuum Units 202V and 202LV

PARTS LIST

Item	Description	Qty	202	202L	202B	202V	202LV
1	Handle Assembly	1			128178		
2	Cable Assembly	1			116404-1		
3	Dowel Pin	1			505496		
4	Pin	1			500621		
5	Trigger	1			124333-1		
6	Piston Assembly (incl. items 16,17,&18)	1	123774	125495	123774	123774-1	125495-1
7	Retaining Nut	1			111795		
8	Adapter	1			123761		
9	Wiper Seal	1			505817		
10	Gland Cap	1			122432		
11	Back-up Ring	1			501110		
12	O-Ring	1			500816		
13	Retaining Ring	1			502274-		
14	Polyseal	1			505818		
15	Front Gland	1			123757		
16	Retaining Ring	1			506653		
17	Washer	1			506654		
18	Polyseal	1			506160		
19	Compression Spring	1			506492		
20	Sticker	1			590240-1		
21	End Cap	1	125150		124341	123577	
22	Spacer / Washer	1			124828		
23	Wiper Seal	1			506488		
24	Pintail Deflector / Bottle	1	124211			123772	
25	Gland Assembly	1			116134-1		
26	Gland Housing	1			125139		
27	O-ring	1			500786		
28	Polyseal	1			506566		
29	Spacer	1			123906		
30	Retaining Ring	1			506565		
31	O-ring	1			500784		
32	Back-up Ring	1			501090		
33	QUAD Ring	1			501414		
34	Bumper	1			116408		
35	Cylinder Assembly	1			123752		
36	Piston, Rod	1			111803-1		
37	Air Piston	1			123753		
38	Retaining Ring	1			506490		
39	Gasket	1			126941-1		
40	Screw	3			504127		

PARTS LIST *continued*

Item	Description	Qty	202	202L	202B	202V	202VL
41	Bottom Plate	1			116585-1		
42	Muffler	1			115554-1		
43	Locknut	1			505420		
44	Washer	1			506493		
45	Cylinder Head	1			111959-1		
46	O-ring	1			500869		
47	QUAD Ring	1			501456		
48	Pivot Screw	1			125118		
49	Spring	1			116272		
50	O-ring	1			504407		
51	Swivel Assembly	1			507164		
52	Throttle Valve	1			115505-1		
53	Throttle Arm	1			123754		
54	Plug/Gasket Assy; Tubing Connector (V models)	1		506576		506675	
55	Plug	1			100309		
56	O-ring	1			505438		
57	O-ring	2			500779		
58	O-ring	1			500778		
59	Sticker	1			590350		
60	Sticker	1			590351		
61	Sticker	1			590347		
62	Retaining Ring	1	-----		501007		
63	Washer	1	-----		506628		
64	Adapter	1	-----			123784	
65	O-ring	2	-----		500790		
66	Retaining Ring	1	-----		502310		
67	Tube	1	-----		128186		
68	O-ring	1	-----		500778		
69	O-ring	1	-----		500807		
70	Tube and Slide Assy Replacement Tube part no. 128043 may be purchased separately.	1	-----		128044		
71	Washer	1	-----		506648		
72	O-ring	2			504408		
73	Lever Guard	1			125117		
74							
75							
76							
77							
78							
79							
80							

TROUBLESHOOTING

Always check out the simplest possible cause of a malfunction first. For example, an air hose not connected. Then proceed logically, eliminating each possible cause until the cause is located. Where possible, substitute known good parts for suspected bad parts. Use TROUBLESHOOTING CHART as an aid in locating and correcting malfunction.

1. *Tool fails to operate when trigger is depressed.*
 - a) Air line not connected or pressure too low
 - b) Throttle Valve O-rings (50) worn or damaged.
 - c) Throttle Valve Cable (2) is broken.
2. *Tool does not complete fastener installation and break pintail.*
 - a) Air pressure too low
 - b) Air Piston Quad-ring (47) worn or damaged.
 - c) Tool is low on hydraulic fluid, refer to Fill and Bleed section.
 - d) Air in hydraulic system, refer to Fill and Bleed section.
3. *Pintail stripped and/or swaged collar not ejected.*
 - a) Check for broken or worn jaws in nose assembly, refer to nose assembly data sheet.
4. *Hydraulic fluid exhausts with air or leaks at base of handle.*
 - a) Worn or damaged Gland Assembly (25), inspect Polyseal (28), O-rings (31 and 27), Quad-ring(33) and Back-up ring (32) replace if necessary.
5. *Hydraulic fluid leaks at rear of Pull Piston (6)*
 - a) Worn or damaged piston Polyseal (18), replace if necessary.
6. *Hydraulic fluid leaks at front of Pull Piston (6).*
 - a) Worn or damaged Front Gland (15), inspect Polyseal (14), O-ring (12) and Back-up Ring (11) replace if necessary.
7. *Pull Piston (6) will not return.*
 - a) Throttle Valve (52) stuck: Lubricate O-rings (50).
 - b) Throttle Arm (53), Cable (2) or Trigger (5) binding.
8. *Air leaks at air Cylinder Head (45).*
 - a) Worn or damaged O-ring (46) replace if necessary.

KITS AND ACCESSORIES

Fill and Bleed Bottle (Fig. 9)	- 120337	Pintail Collection Bag (202 & 202L)	- 125652
Stall Nut (202, 202B, & 202V)	- 124090	Conversion Kit	- 124173
Stall Nut (202L & 202LV)	- 125340	<i>(To convert 202 to 202V)</i>	
202, 202B, & 202V		<i>Includes:</i>	
Assembly Tool Kit	- 123110-2	Piston Assembly 202V	- 123774-1
<i>Includes: (Fig. 3)</i>		End Cap Assembly	- 124246
Piston Assembly (Bullet)	- 123111-2	Tubing & Slide Assembly	- 124245
Spacer	- 123112-2	Straight Connector	- 506675
POLYSEAL Tool	- 121694-202	Vacuum Attach Adapter	- 123784
202L & 202LV		Pintail Collection Bottle	- 123772
Assembly Tool Kit	- 123110-8	Flat Washer	- 506628
<i>Includes: (Fig. 3)</i>		Retaining Ring Ext	- 501007
Piston Assembly (Bullet)	- 123111-4	1/8 Hex Key (used on Item 40, fig 14)	- 502294
Spacer	- 123112-3	5/32 Hex Key (used on Item 48, fig 14)	- 502295
POLYSEAL Tool	- 121694-202	Retaining Ring Pliers	- 502866
Service Kit (202, 202B, & 202L)	- 202KIT		
Service Kit (202LV & 202V)	- 202VKIT		
Suspension Spring	- 124447		

LIMITED WARRANTIES

Tooling Warranty: Huck warrants that tooling and other items (excluding fasteners, and hereinafter referred as "other items") manufactured by Huck shall be free from defects in workmanship and materials for a period of ninety (90) days from the date of original purchase.

Warranty on "non standard or custom manufactured products": With regard to non-standard products or custom manufactured products to customer's specifications, Huck warrants for a period of ninety (90) days from the date of purchase that such products shall meet Buyer's specifications, be free of defects in workmanship and materials. Such warranty shall not be effective with respect to non-standard or custom products manufactured using buyer-supplied molds, material, tooling and fixtures that are not in good condition or repair and suitable for their intended purpose.

THERE ARE NO WARRANTIES WHICH EXTEND BEYOND THE DESCRIPTION ON THE FACE HEREOF. HUCK MAKES NO OTHER WARRANTIES AND EXPRESSLY DISCLAIMS ANY OTHER WARRANTIES, INCLUDING IMPLIED WARRANTIES AS TO MERCHANTABILITY OR AS TO THE FITNESS OF THE TOOLING, OTHER ITEMS, NONSTANDARD OR CUSTOM MANUFACTURED PRODUCTS FOR ANY PARTICULAR PURPOSE AND HUCK SHALL NOT BE LIABLE FOR ANY LOSS OR DAMAGE, DIRECTLY OR INDIRECTLY, ARISING FROM THE USE OF SUCH TOOLING, OTHER ITEMS, NONSTANDARD OR CUSTOM MANUFACTURED PRODUCTS OR BREACH OF WARRANTY OR FOR ANY CLAIM FOR INCIDENTAL OR CONSEQUENTIAL DAMAGES.

Huck's sole liability and Buyer's exclusive remedy for any breach of warranty shall be limited, at Huck's option, to replacement or repair, at FOB Huck's plant, of Huck manufactured tooling, other items, nonstandard or custom products found to be defective in specifications, workmanship and materials not otherwise the direct or indirect cause of Buyer supplied molds, material, tooling or fixtures. Buyer shall give Huck written notice of claims for defects within the ninety (90) day warranty period for tooling, other items, nonstandard or custom products described above and Huck shall inspect products for which such claim is made.

Tooling, Part(s) and Other Items not manufactured by Huck.

HUCK MAKES NO WARRANTY WITH RESPECT TO THE TOOLING, PART(S) OR OTHER ITEMS MANUFACTURED BY THIRD PARTIES. HUCK EXPRESSLY DISCLAIMS ANY WARRANTY EXPRESSED OR IMPLIED, AS TO THE CONDITION,

DESIGN, OPERATION, MERCHANTABILITY OR FITNESS FOR USE OF ANY TOOL, PART(S), OR OTHER ITEMS THEREOF NOT MANUFACTURED BY HUCK. HUCK SHALL NOT BE LIABLE FOR ANY LOSS OR DAMAGE, DIRECTLY OR INDIRECTLY, ARISING FROM THE USE OF SUCH TOOLING, PART(S) OR OTHER ITEMS OR BREACH OF WARRANTY OR FOR ANY CLAIM FOR INCIDENTAL OR CONSEQUENTIAL DAMAGES.

The only warranties made with respect to such tool, part(s) or other items thereof are those made by the manufacturer thereof and Huck agrees to cooperate with Buyer in enforcing such warranties when such action is necessary.

Huck shall not be liable for any loss or damage resulting from delays or nonfulfillment of orders owing to strikes, fires, accidents, transportation companies or for any reason or reasons beyond the control of the Huck or its suppliers.

Huck Installation Equipment

Huck International, Inc. reserves the right to make changes in specifications and design and to discontinue models without notice.

Huck Installation Equipment should be serviced by trained service technicians only.

Always give the Serial Number of the equipment when corresponding or ordering service parts.

Complete repair facilities are maintained by Huck International, Inc. Please contact one of the offices listed below.

Eastern

One Corporate Drive Kingston, New York 12401-0250
Telephone (845) 331-7300 FAX (845) 334-7333

Canada

6150 Kennedy Road Unit 10, Mississauga, Ontario, L5T2J4, Canada.
Telephone (905) 564-4825 FAX (905) 564-1963

Outside USA and Canada

Contact your nearest Huck International Office, see back cover.

In addition to the above repair facilities, there are Authorized Tool Service Centers (ATSC's) located throughout the United States. These service centers offer repair services, spare parts, Service Parts Kits, Service Tools Kits and Nose Assemblies. Please contact your Huck Representative or the nearest Huck office listed on the back cover for the ATSC in your area.



For the Long Haul™

A Global Organization

Alcoa Fastening Systems (AFS) maintains company offices throughout the United States and Canada, with subsidiary offices in many other countries. Authorized AFS distributors are also located in many of the world's

industrial and Aerospace centers, where they provide a ready source of AFS fasteners, installation tools, tool parts, and application assistance.

Alcoa Fastening Systems world-wide locations:

Americas

Alcoa Fastening Systems

Aerospace Products

Tucson Operations

3724 East Columbia
Tucson, AZ 85714
800-234-4825
520-747-9898
FAX: 520-748-2142

Alcoa Fastening Systems

Aerospace Products

Carson Operations

PO Box 5268
900 Watson Center Rd.
Carson, CA 90749
800-421-1459
310-830-8200
FAX: 310-830-1436

Alcoa Fastening Systems

Commercial Products

Waco Operations

PO Box 8117
8001 Imperial Drive
Waco, TX 76714-8117
800-388-4825
254-776-2000
FAX: 254-751-5259

Alcoa Fastening Systems

Commercial Products

Kingston Operations

1 Corporate Drive
Kingston, NY 12401
800-431-3091
845-331-7300
FAX: 845-334-7333
www.hucktools.com

Alcoa Fastening Systems

Commercial Products

Canada Operations

6150 Kennedy Road, Unit 10
Mississauga, Ontario L5T2J4
Canada
905-564-4825
FAX: 905-564-1963

Alcoa Fastening Systems

Commercial Products

Latin America Operations

Avenida Parque Lira. 79-402
Tacubaya Mexico, D.F.
C.P. 11850
FAX: 525-515-1776
TELEX: 1173530 LUKSME

Far East

Alcoa Fastening Systems

Commercial Products

Australia Operations

14 Viewtech Place
Rowville, Victoria
Australia 3178
03-764-5500
Toll Free: 008-335-030
FAX: 03-764-5510

Europe

Alcoa Fastening Systems

Commercial Products

United Kingdom Operations

Unit C, Stafford Park 7
Telford, Shropshire
England TF3 3BQ
01952-290011
FAX: 0952-290459

Alcoa Fastening Systems

Aerospace Products

France Operations

Clos D'Asseville
BP4
95450 Us Par Vigny
France
33-1-30-27-9500
FAX: 33-1-34-66-0600

For The Long Haul, The Future of Fastening Technology, The Future of Assembly Technology, The Future of Tooling Technology, and Tools of Productivity are service marks of Huck International. Huck provides technical assistance regarding the use and application of Huck fasteners and tooling.

NOTICE: The information contained in this publication is only for general guidance with regard to properties of the products shown

and/or the means for selecting such products, and is not intended to create any warranty, express, implied, or statutory; all warranties are contained only in Huck's written quotations, acknowledgements, and/or purchase orders. It is recommended that the user secure specific, up-to-date data and information regarding each application and/or use of such products.

HWB898 1003-5M



Alcoa Fastening Systems



One Great ConnectionSM